



Galvanised Tapers

ADS's galvanised Tapers are spot welded and made as standard from 0.9mm galvanised sheet.

Calculation of the length L of the taper:

The difference between the large and the small diameter (D-d) of the taper is plotted on the vertical axis (y) in the system of co-ordinates. By following the line from this point to the intersection, the length L is read in the corresponding point on the horizontal axis (x) in the system of co-ordinates.

When mounting with Wide Pull Rings, Rapid Pull Rings and flanges the length L is increased by 2 x 50mm.

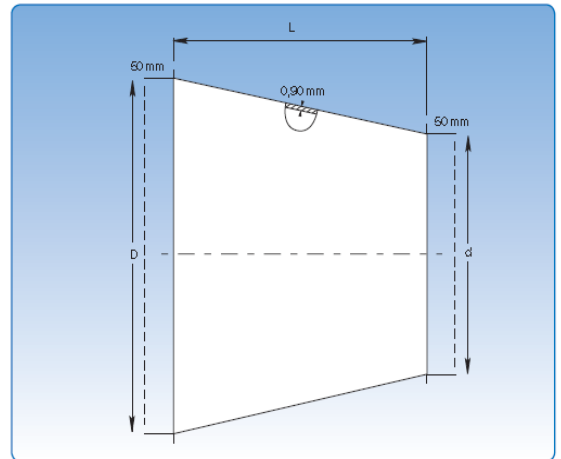

Diameter: 80-1000mm

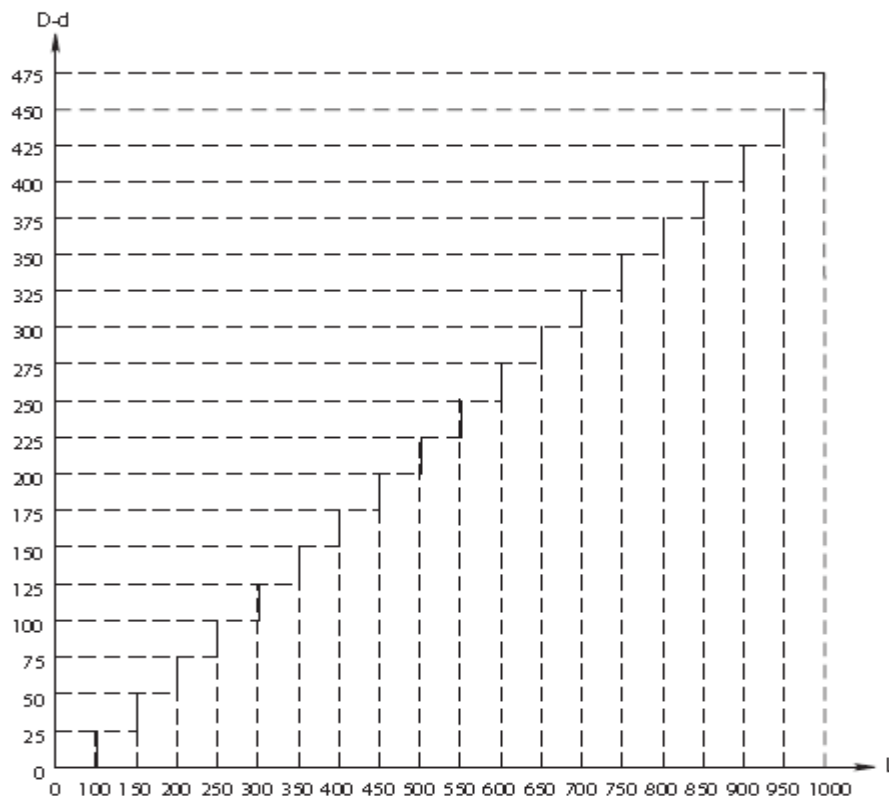

Tapers with dimensions other than those listed are available upon request.



3/11 Cooper Street, Campbellfield, Melbourne VIC 3061

Phone: 03 8339 0894 Fax: 03 8339 0871

E-mail: vicsales@adsduct.com.au

1/595 Woodstock Avenue, Glendenning, Sydney NSW 2761

Phone: 02 9675 4546 Fax: 02 9675 4570

E-mail: nswsales@adsduct.com.au

Web Site: www.ductsystems.com.au

1300 DUCT4U (1300 38 28 48)

