

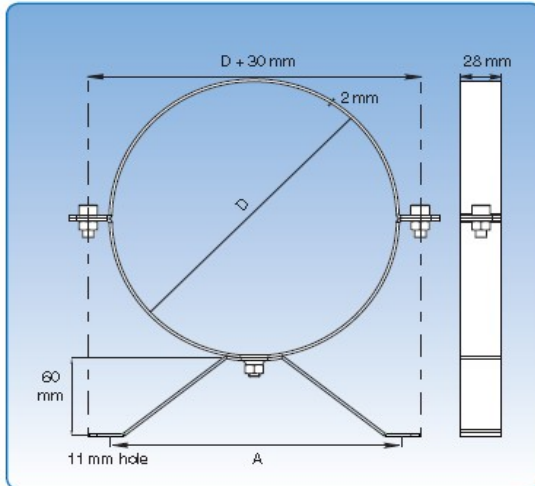

# Galvanised Mounting Brackets Standard / Heavy

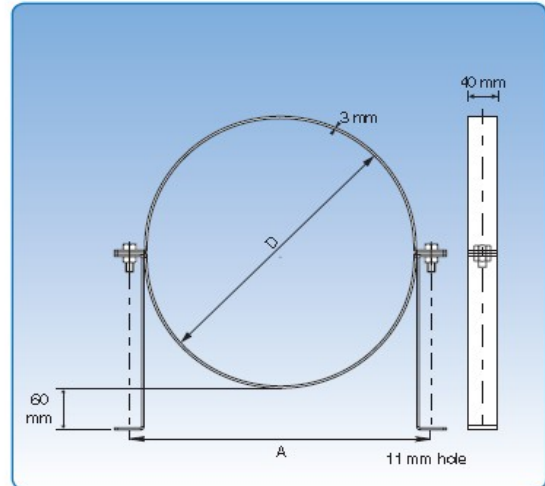

**Diameter: 80-300mm**



**Diameter: 315-800mm**

ADS's Mounting Brackets are designed for suspension of the duct systems. The brackets are available in three different mounting principles: with legs, wall mounted and hanging. With regard to the distance between the brackets, it is recommended to apply one bracket every second duct assembly.

## Dimensional Specifications

D mm	Part #	A mm	Weight kg	D mm	Part #	A mm	Weight kg
80	GMBS080	132	0.10	315	GMBH315	210	0.35
100	GMBS100	132	0.12	325	GMBH325	355	2.00
120	GMBS120	132	0.15	350	GMBH350	240	1.66
125	GMBS125	132	0.33	375	GMBH375	405	2.00
140	GMBS140	132	0.35	400	GMBH400	451	1.83
150	GMBS150	132	0.36	450	GMBH450	501	2.01
160	GMBS160	132	0.38	500	GMBH500	551	2.27
180	GMBS180	210	0.43	550	GMBH550	601	2.33
200	GMBS200	210	0.46	600	GMBH600	651	2.42
225	GMBS225	210	0.50	630	GMBH630	660	3.00
250	GMBS250	210	0.53	650	GMBH650	701	3.64
275	GMBS275	210	0.57	700	GMBH700	761	3.88
300	GMBS300	210	0.60	750	GMBH750	811	4.09
				800	GMBH800	861	4.31

**NB: Legs are sold separately**  
Code: GLS...



**NB: Legs are sold separately**  
Code: GLH...



3/11 Cooper Street, Campbellfield, Melbourne VIC 3061

Phone: 03 8339 0894 Fax: 03 8339 0871

E-mail: [vicsales@adsduct.com.au](mailto:vicsales@adsduct.com.au)

1/595 Woodstock Avenue, Glendenning, Sydney NSW 2761

Phone: 02 9675 4546 Fax: 02 9675 4570

E-mail: [nswsales@adsduct.com.au](mailto:nswsales@adsduct.com.au)

Web Site: [www.ductsystems.com.au](http://www.ductsystems.com.au)

1300 DUCT4U (1300 38 28 48)

