

Galvanised Tight Slide Gate Manual / Pneumatic

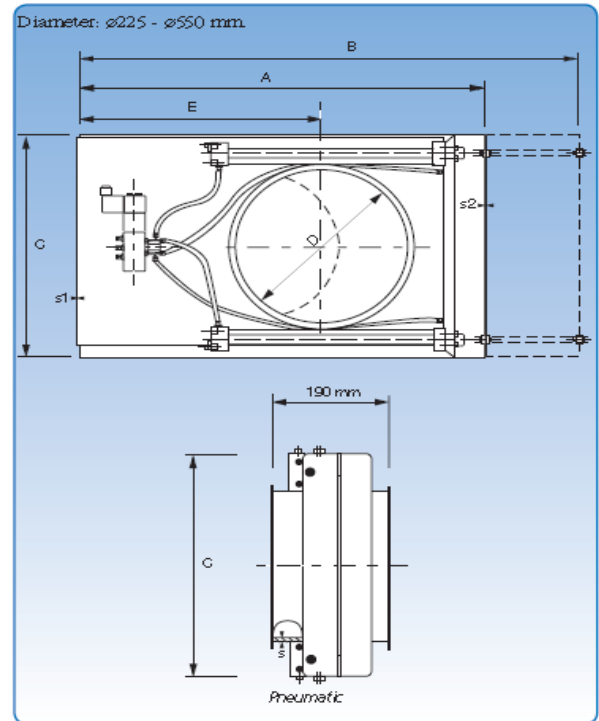
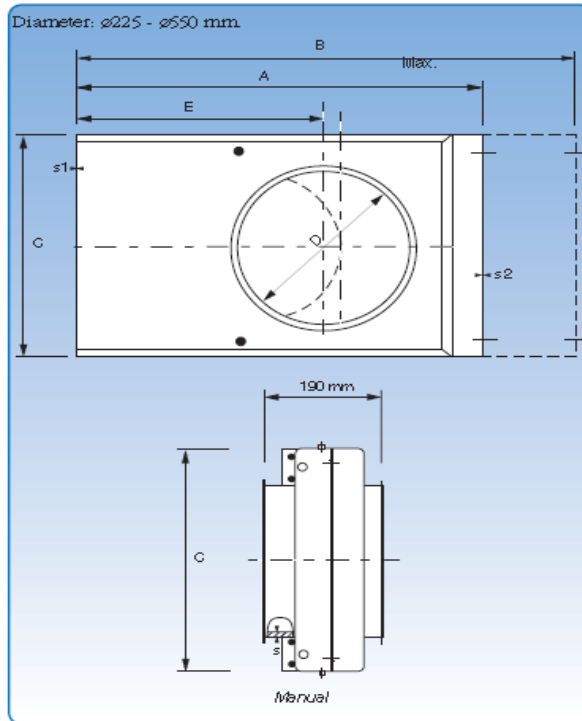

General

ADS's Tight Slide Gate Manual is made from pressed half-parts of 1.5-2.0mm galvanised sheet.

The sliding gates slide smoothly in gaskets of polyether and PEHD to ensure optimal tightness.

Diameter: 225-550mm

With Pneumatic Actuator

The pneumatic gate is fitted with 2 pneumatic cylinders running in parallel.

Solenoid valve: monostable 5/2 valve with 1 x 230V AC-50/60Hz electric coil or 24V DC. Pneumatic pressure: 4-6 bar.

Diameter: 225-550mm

Dimensional Specifications

D mm	Part # Manual	Part # Pneu.	s mm	s1 mm	s2 mm	A mm	B max. mm	C mm	E mm	Weight (Man.) Kg	Weight (Pneu.) kg
225	TSGM225	TSGP225	1.50	1.50	2.50	580	830	360	390	10.70	13.40
250	TSGM250	TSGP250	1.50	1.50	2.50	660	960	385	455	14.00	15.00
275	TSGM275	TSGP275	2.00	2.00	3.00	680	980	410	465	17.60	19.78
300	TSGM300	TSGP300	2.00	2.00	3.00	725	1045	435	495	18.90	21.00
350	TSGM350	TSGP350	2.00	2.00	3.00	855	1255	485	600	24.60	26.00
400	TSGM400	TSGP400	2.00	2.50	3.00	1005	1505	545	725	35.60	36.84
450	TSGM450	TSGP450	2.00	2.50	3.00	1055	1555	595	750	40.60	44.60
500	TSGM500	TSGP500	2.00	3.00	3.00	1140	1670	645	805	50.50	56.20
550	TSGM550	TSGP550	2.00	3.00	3.00	1301	1901	691	915	60.70	65.30

Slide Gates with dimensions other than those listed are available upon request.



3/11 Cooper Street, Campbellfield, Melbourne VIC 3061

Phone: 03 8339 0894 Fax: 03 8339 0871

E-mail: vicsales@adsduct.com.au

1/595 Woodstock Avenue, Glendenning, Sydney NSW 2761

Phone: 02 9675 4546 Fax: 02 9675 4570

E-mail: nswsales@adsduct.com.au

Web Site: www.ductsystems.com.au

1300 DUCT4U (1300 38 28 48)

