

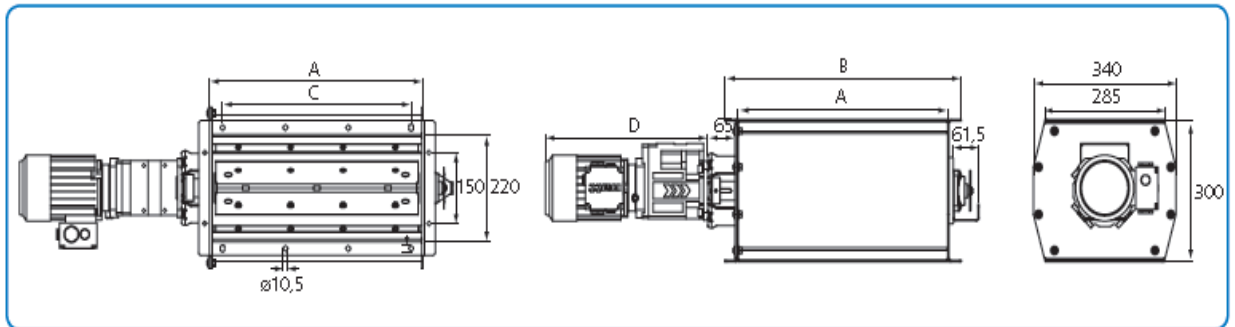

# Standard Throughput Rotary Valve



ADS's Rotary Valve, Type STRV-S, has 6 rotor arms with Hard-wearing rubber blades bolted to them. The rotor shaft is directly coupled to a geared motor and attached by a flanged bearing at the opposite end. A tight connection between the rotor and the rotor housing, both made from 3mm thick steel plate, is ensured by the mounting of rubber seals. The units are painted in RAL 5010.

### Dimensions: 250-2000

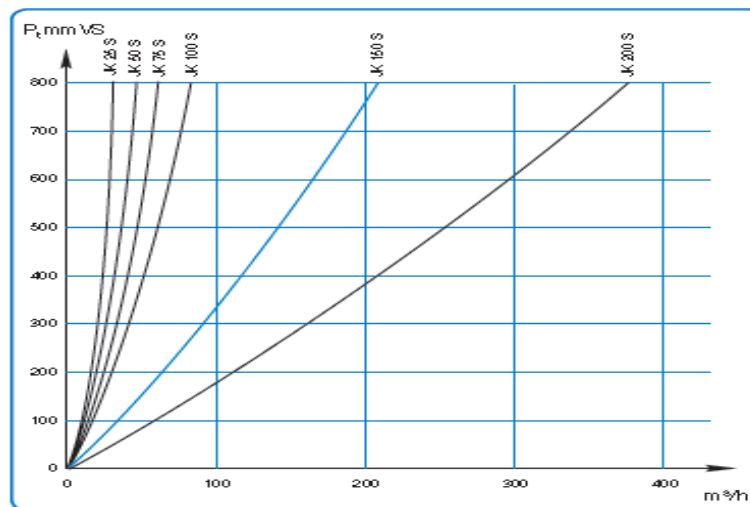

### Dimensional Specifications

Part #	kW	A mm	B mm	C mm	D mm	Weight kg	Revs/min	Output at 50% full
STRV25-S	0.55	250	315	1 x 150	350	45	20	10m <sup>3</sup> /hr
STRV50-S	0.55	500	565	3 x 150	415	65	20	20m <sup>3</sup> /hr
STRV75-S	0.55	750	815	4 x 150	387	73	20	32m <sup>3</sup> /hr

Valves with dimensions other than those listed are available upon request.



3/11 Cooper Street, Campbellfield, Melbourne VIC 3061

Phone: 03 8339 0894 Fax: 03 8339 0871

E-mail: [vicsales@adsduct.com.au](mailto:vicsales@adsduct.com.au)

1/595 Woodstock Avenue, Glendenning, Sydney NSW 2761

Phone: 02 9675 4546 Fax: 02 9675 4570

E-mail: [nswsales@adsduct.com.au](mailto:nswsales@adsduct.com.au)

Web Site: [www.ductsystems.com.au](http://www.ductsystems.com.au)

1300 DUCT4U (1300 38 28 48)

