

# Galvanised Tight Slide Gate Manual/Pneumatic

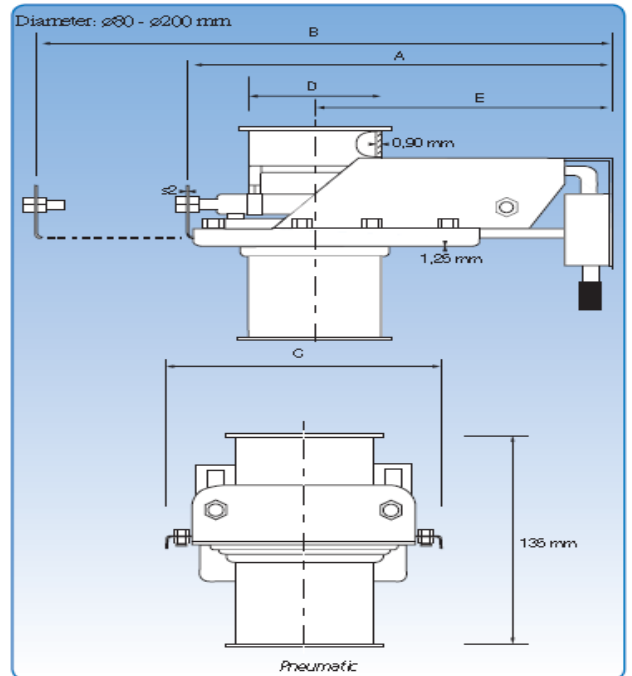
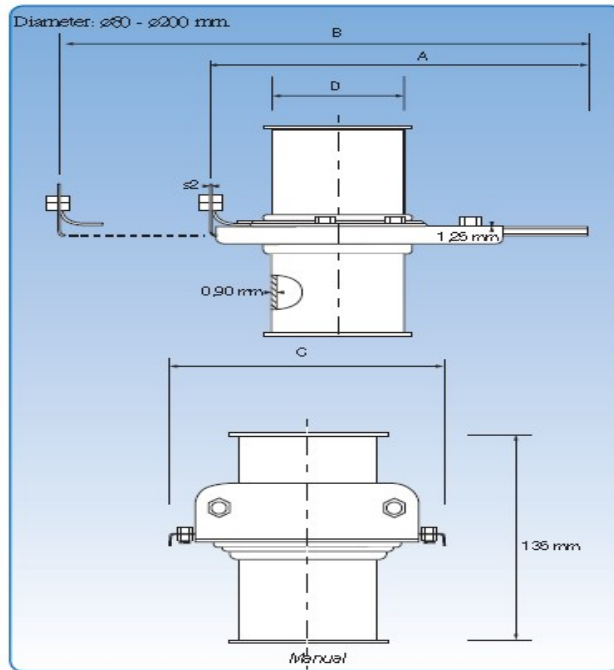

## General

ADS's Tight Slide Gate Manual is made from pressed half-parts of 1.25mm galvanised sheet.

The sliding gates slide smoothly in gaskets of polyether and PEHD to ensure optimal tightness.

**Diameter: 80-200mm**

## With Pneumatic Actuator

The pneumatic gate is fitted with 2 pneumatic cylinders running in parallel.

Solenoid valve: monostable 5/2 valve with 1 x 230V AC-50/60Hz electric coil or 24V DC.

Pneumatic pressure: 4-6 bar

**Diameter: 80-200mm**

## Dimensional Specifications

D	Part #	Part #	s2	A (Man.)	A (Pneu.)	B (Man.)	B (Pneu.)	C	E	Weight (Man.)	Weight (Pneu.)
mm	Manual	Pneu.	mm	mm	mm	mm	mm	mm	mm	Kg	kg
80	TSGM080	TSGP080	1.50	225	260	320	355	160	190	1.20	2.30
100	TSGM100	TSGP100	1.50	265	305	380	415	190	225	1.50	3.80
125	TSGM125	TSGP125	2.00	325	360	460	500	215	260	2.10	3.60
140	TSGM140	TSGP140	2.00	375	415	540	580	240	300	2.90	3.80
150	TSGM150	TSGP150	2.00	375	415	540	580	240	300	2.90	4.40
160	TSGM160	TSGP160	2.00	405	445	585	620	250	325	3.20	4.90
180	TSGM180	TSGP180	2.00	455	495	655	695	290	355	4.10	6.00
200	TSGM200	TSGP200	2.00	485	525	705	745	300	385	4.40	6.30

Slide Gates with dimensions other than those listed are available upon request.



3/11 Cooper Street, Campbellfield, Melbourne VIC 3061

Phone: 03 8339 0894 Fax: 03 8339 0871

E-mail: [vicsales@adsduct.com.au](mailto:vicsales@adsduct.com.au)

1/595 Woodstock Avenue, Glendenning, Sydney NSW 2761

Phone: 02 9675 4546 Fax: 02 9675 4570

E-mail: [nswsales@adsduct.com.au](mailto:nswsales@adsduct.com.au)

Web Site: [www.ductsystems.com.au](http://www.ductsystems.com.au)

1300 DUCT4U (1300 38 28 48)

